

AGRIA HISPANIA, S.A.



MAQUINARIA PARA LA CONSTRUCCIÓN CONSTRUCTION MACHINERY

MACHINERIE POUR LE CONSTRUCTION DES BATIMENTS ET TT. PP.



TARIFA DE PRECIOS PRICE LIST *TABLEAU DE PRIX*



2014



AGRIA HISPANIA, S.A.

es una sociedad fundada en 1958, dedicada a la fabricación de maquinaria agrícola y para la construcción, así como a la fabricación de componentes para transmisiones mecánicas y mecanizados de todo tipo de componentes.

Desde nuestra fundación, el diseño, la calidad y el servicio han sido las principales premisas de la empresa, lo que ha hecho que, en la actualidad **AGRIA HISPANIA, S.A.** sea empresa líder en el sector y que nuestros productos se exporten a los 5 continentes, colaborando en el desarrollo de estos sectores.

AGRIA HISPANIA, S.A.

was founded in 1958 and dedicates itself to the manufacture of construction and agricultural machinery, and manufactures components for mechanical transmission and machining of all type of components.

Since our foundation, the company has been mostly concerned with design, quality and service. As a result, AGRIA HISPANIA, S.A. has become a leader in the sector and exports its products to countries all over the 5 continents, thereby contributing to the development of these areas.

AGRIA HISPANIA, S.A.

est une société fondée en 1958, spécialisée dans la fabrication de machines pour les travaux publics, bâtiment et l'agriculture; et aussi, la fabrication de composants pour transmissions mécaniques et mécanisation de tous types de composants.

Depuis sa création, **AGRIA HISPANIA, S.A.** a basé sa stratégie sur la conception du produit, la qualité et le service. Ceci lui a permis de se positionner en leader dans son secteur et d'exporter ses produits vers tous les continents, contribuant ainsi au développement de ces secteurs.

Índice • Index • Indice

• Historia • History • Histoire	pag 2
• Índice • Index • Indice	pag 3
• Dumper Mecánico • 1.600 Kgs. • Dumper • Dumper • (160, 160 DA, 160 DG, 160 HG, 160 P)	pag 4-5
• Dumpers hidrostáticos • 2.000 - 2.500 Kgs. • Hydrostatic dumpers • Dumpers hydrostatiques • (200 H • 250 H / 200 PH • 250 PH)	pag 6-7
• Dumpers hidrostáticos • 3.500 - 4.000 Kgs. • Hydrostatic dumpers • Dumpers hydrostatiques • (350 AHG • 400 AHG)	pag 8-9
• Dumpers hidrostáticos • 6.000 Kgs. • Hydrostatic dumpers • Dumpers hydrostatiques • (DH-600 AHG)	pag 10-11
• Carretillas elevadoras • 1.600 Kgs • Forklifts • Chariots Elevateurs • (TH-160)	pag 12-13
• Carretillas elevadoras • 1.700 Kgs. • Forklifts • Chariots Elevateurs • (TH-175 C)	pag 14-15
• Carretillas elevadoras • 2.100 Kgs. • Forklifts • Chariots Elevateurs • (TH-210)	pag 16-17
• Carretillas elevadoras • 2.500 Kgs. • Forklifts • Chariots Elevateurs • (TH-250)	pag 18-19
• Carretillas elevadoras • 3.000 Kgs. • Forklifts • Chariots Elevateurs • (TH-300)	pag 20-21
• Carretillas elevadoras • 3.500 Kgs. • Forklifts • Chariots Elevateurs • (TH-350)	pag 22-23
• Pala Cargadora • Wheel loader • Pelle Chargeur • (P-650)	pag 24-25
• Dumper Barredora • Dumper-Sweeper • Dumper-Balayeuse • (DH-200 BA)	pag 26-27



• DH - 160 • DUMPER

Modelos • Models • Modèles

- DH - 160
- DH - 160 DA
- DH - 160 DG
- DH - 160 HG
- DH - 160 P



DH-160

DH-160 DA

DH-160 DG

DH-160 HG

DH-160 P

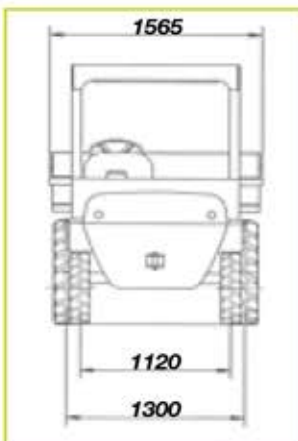

Dimensiones • Dimensions • Dimensions

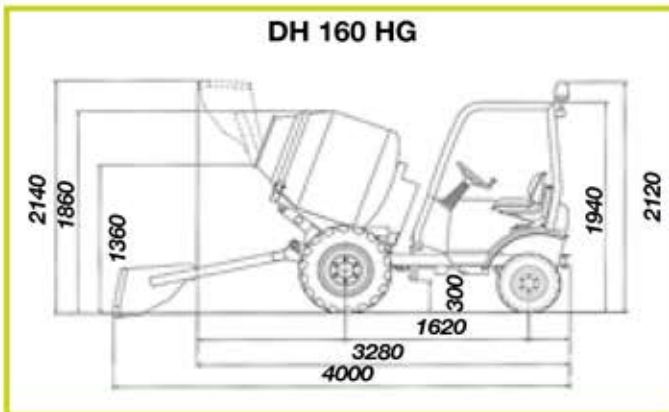
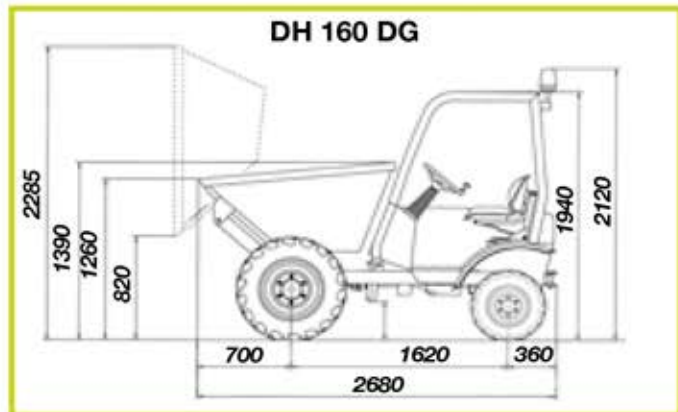
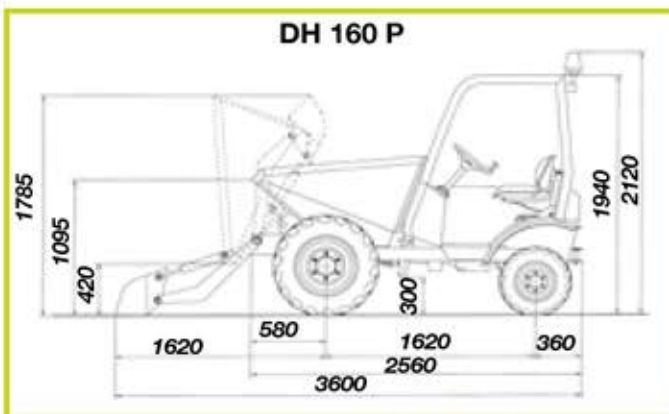
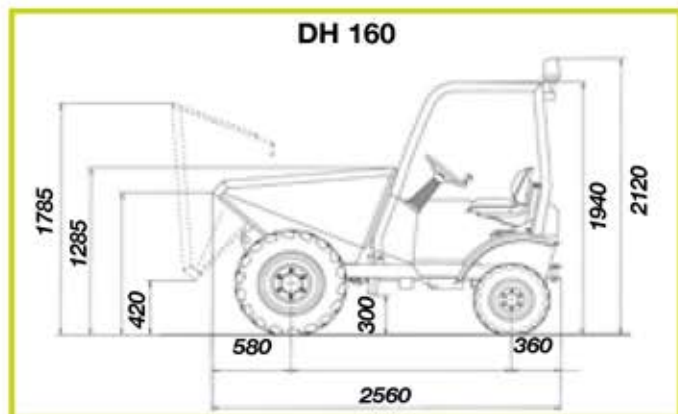

• DH - 160 • DUMPER

Características Técnicas • Technical Features • Caracteristiques Techniques



CARGA ÚTIL (Kg.)	1.600 Kgs. • 1,05 m ³ • Nivel de agua 615 litros
MOTOR	Lombardini, 11KW/15CV/16HP
REFRIGERACIÓN	Agua
ARRANQUE	Eléctrico
TRACCIÓN	4 x 2 / 4 x 4 accionamiento mecánico
VELOCIDADES	4 AV + 4 M.A. / Inversor • Velocidad máxima 20 Km/h.
TRANSMISIÓN	Piñón Corona
DIRECCIÓN	Hidráulica
FRENOS	Accionamiento hidráulico
NEUMATICOS	DH 160 4x4 Del: 10.0 / 75 - 15,3 • Tras: 20 x 8,50 / 12 • DH160 4x2 Del 100/75-1.5,3. Tras: 20 x 8,50 / 12
DESCARGA HIDRÁULICA	Si
RADIO DE GIRO (m.)	Interior: 1,60 • Exterior: 3,50
PESO EN VACÍO (Kg.)	4x4: DH-160: 1.035 / DH-160 P: 1.140 / DH-160 HG: 1.240 / DH-160 DG: 1.120 / DH-160 DA: 1.200 Kgs. 4x2: DH-160: 995 / DH-160 P: 1.175 / DH-160 HG: 1.375 / DH-160 DG: 1.155 / DH-160 DA: 1.135 Kgs.
CARACTERÍSTICAS	Horómetro, protección antivandálica, avisador acústico de seguridad M.A., dispositivo de seguridad antiarranque, techo protector, girofaro, espejo retrovisor y cinturón de seguridad.



USEFULL LOAD	1.600 Kgs. • 1,05 m ³ • Water level 615 liters
ENGINE	Lombardini, 11KW/15CV/16HP
COOLING SYSTEM	Water
STARTER	Electrical
TRACTION	4 x 2 / 4 x 4 working mechanically
SPEEDS	4 forward + 4 reverse / Inversor device • Maximun speed 20 Km/h.
TRANSMISSION	Pinnion Crown
STEERING	Hydraulic
BRAKES	Hydraulic drive
TYRES	DH 160 4x4 Front: 10.0 / 75 - 15,3 • Rear: 20 x 8,50 / 12 • DH160 4x2: 10.0/75 - 15,3 and 20 x 8,50 / 12
HYDRAULICAL DUMPING	Yes
TURNING RADIUS (m.)	Inner: 1,60 • Outer: 3,50
NET WEIGHT (Kg.)	4x4: DH-160: 1.035 / DH-160 P: 1.140 / DH-160 HG: 1.240 / DH-160 DG: 1.120 / DH-160 DA: 1.200 Kgs. 4x2: DH-160: 995 / DH-160 P: 1.175 / DH-160 HG: 1.375 / DH-160 DG: 1.155 / DH-160 DA: 1.135 Kgs.
FEATURES	Hour meter, rear speed acoustical adviser, anti-starter security device, protector roof, head light turning, rear -view mirror and safety belt.



CHARGE UTILE	1.600 Kgs. • 10,5 m ³ • Niveau de eau 615 litres
MOTEUR	Lombardini, 11KW/15CV/16HP
REFRIGERATION	Eau
DÉMARRAGE	Électrique
TRACTION	4 x 2 / 4 x 4 commande mécanique
VITESSES	4 avant + 4 arrière / Inverseur • Vitesse max. 20 Km/h
TRANSMISSION	Pignon couronne
DIRECTION	Hydraulique
FREINS	Entraînement hydraulique
ROUES	DH 160 4x4 Avant: 10.0 / 75 - 15,3 • Arrière: 20 x 8,50 / 12 • DH160 4x2: 10.0/75 - 15,3 et 20 x 8,50 / 12
DÉCHARGE HYDRAULIQUE	Oui
RAYON DE BRACAGE (m.)	Interieur: 1,60 • Exterieur 3,50
POIDS A VIDE (Kg.)	4x4: DH-160: 1.035 / DH-160 P: 1.140 / DH-160 HG: 1.240 / DH-160 DG: 1.120 / DH-160 DA: 1.200 Kgs. 4x2: DH-160: 995 / DH-160 P: 1.175 / DH-160 HG: 1.375 / DH-160 DG: 1.155 / DH-160 DA: 1.135 Kgs.
CHARACTERISTIQUES	Horomètre, avertisseur acoustique de sécurité marche arrière, dispositif de sécurité anti-démarrage, toit protecteur, phare tournant, miroir rétroviseur et ceinture de sécurité.

Tarifa de Precios • Tariff of Prices • Tarif de Prix

REF: Descripción • Description • Description

DH - 160
DH - 160 DA
DH - 160 DG
DH - 160 P
DH - 160 HG

1579 AM Equipo de luces / Front lights / Eclairage routier

MACIZ - DH - 160 Macizado de las 4 ruedas / Wheel fill up / Remplissement des 4 roues

• Dumpers hidrostáticos

• Hydrostatic dumpers • Dumpers hydrostatiques

Modelos • Models • Modèles

- DH - 200 H
- DH - 250 H
- DH - 200 PH
- DH - 250 PH



	H 3	H 4	L 3	Via delantera / L6 / Via trasera	
DH - 200 H	1.200	240	2.990	1.290	1.340
DH - 250 H	1.340	315	1.300	1.300	1.340

Dimensiones • Dimensions • Dimensions

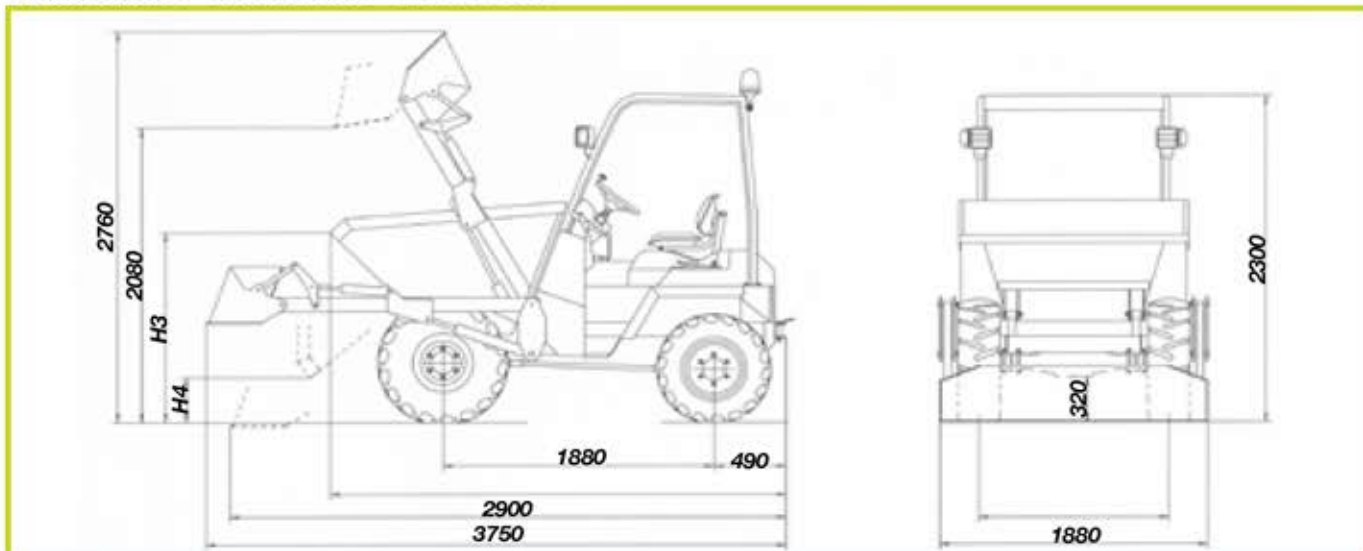

• DH - 200 / 250 H • DUMPERS

Características Técnicas • Technical Features • Caracteristiques Techniques



CARGA ÚTIL	2.000 Kgs	2.500 Kgs
NIVEL AGUA	835 L	980 L
COLMADA	1,2 m ³	1,35 m ³
PENDIENTE MAX.	42%	42%
MOTOR	Diesel Perkins 3 Cilindros. 24,4 KW / 33,2 CV / 36,50 HP . Refigerado por agua	Diesel Perkins 3 Cilindros. 24,4 KW / 33,2 CV / 36,50 HP. Refigerado por agua
TRANSMISIÓN	Hidrostática REXROTH .	Hidrostática REXROTH.
VELOCIDADES	Lenta: 0 - 9 Km/h · Rápida: 0 - 20 Km/h	Lenta: 0 - 9 Km/h · Rápida: 0 - 20 Km/h
DIRECCIÓN	Hidráulica sobre puente trasero	Hidráulica sobre puente trasero
NEUMÁTICOS	Delanteras: 10,0/75-15,3 / Traseras: 8,0 / 75 -15,3	Delanteras: 11,5 / 80-15,3 /Traseras: 10,0 / 75 -15,3
FRENOS	De servicio: Sobre eje delantero De estacionamiento: Sobre eje delantero	De servicio: Sobre eje delantero De estacionamiento: Sobre eje delantero
PESO	200 H: 1.650 200 PH: 1.920	250 H: 1.785 250 PH: 2.055



USEFUL LOAD	2.000 Kgs	2.500 Kgs
WATER LEVEL	835 L	980 L
FULL TO THE BRIM	1,2 m ³	1,35 m ³
MAX. GRADABILITY	42%	42%
ENGINE	Perkins Diesel 3 Cylinders. 24,4 KW / 33,2 CV / 36,50 HP. Water cooled	Perkins Diesel 3 Cylinders. · 24,4 KW / 33,2 CV / 36,50 HP. Water cooled
TRANSMISSION	Hydrostatic REXROTH.	Hydrostatic REXROTH.
SPEEDS	Slow: 0 - 9 Km/h · High: 0 - 20 Km/h	Slow: 0 - 9 Km/h · High: 0 - 20 Km/h
STEERING	Hydraulic on the rear axle	Hydraulic on the rear axle
WHEELS	Front: 10,0/75-15,3 · Rear: 8,0 / 75 -15,3	Front: 11,5 / 80-15,3 · Rear: 10,0 / 75 -15,3
BRAKES	Service brake on rear axle parking brake on the rear axle	Service brake on rear axle parking brake on the rear axle
WEIGHT	200 H: 1.650 200 PH: 1.920	250 H: 1.785 250 PH: 2.055



CHARGE UTILE	2.000 Kgs	2.500 Kgs
NIVEAU DE EAU	835 L	980 L
PLEIN	1,2 m ³	1,35 m ³
DECLIVITE MAX	42%	42%
MOTEUR	Diesel Perkins 3 Cylindres. 24,4 KW / 33,2 CV / 36,50 HP. Par eau	Diesel Perkins 3 Cylindres. 24,4 KW / 33,2 CV / 36,50 HP. Per eau
TRANSMISSION	Hydrostatique REXROTH.	Hydrostatique REXROTH.
VITESSES	Lente: 0 - 9 Km/h · Rapide: 0 - 20 Km/h	Lente: 0 - 9 Km/h · Rapide: 0 - 20 Km/h
DIRECTION	Direction hydraulique pont arriere	Direction hydraulique pont arriere
ROUES	Avant: 1,0/75-15,3 · Arriere: 8,0 / 75 -15,3	Avant: 11,5 / 80-15,3 · Arriere: 10,0 / 75 -15,3
FREINS	De service: pont arriere · Stationnement:pont	De service: pont arriere · Stationnement:pont
POIDS	arriere 200 H: 1.650 200 PH: 1.920	arriere 250 H: 1.785 250 PH: 2.055

Tarifa de Precios • Tariff of Prices • Tarif de Prix

REF:	Descripción • Description • Description	Euros
DH - 200 H		
DH - 250 H		
DH - 200 PH		
DH - 250 PH		
AS-DH - 200 H	Arco de seguridad / Security rope / Arceau de securité	
MACIZ - DH - 200	Macizado de las 4 ruedas / Wheel fill up / Remplissement des 4 roues	

• Dumpers hidrostáticos

• Hydrostatic dumpers • Dumper hydrostatiques

Modelos • Models • Modèles

- DH - 350 AHG
- DH - 400 AHG



	DH-350 AHG	DH-400 AHG
A	3.700	3.865
B	2.700	2.735
C	1.715	1.815
D	2.000	2.000
E	740	740
G (Via delantera)	1.420	1.520
H (Via trasera)	1.420	1.520
Radio Giro Exterior	3,90 m	3,95 m
Radio Giro Interior	2,18 m	2,14 m

Dimensiones • Dimensions • Dimensions

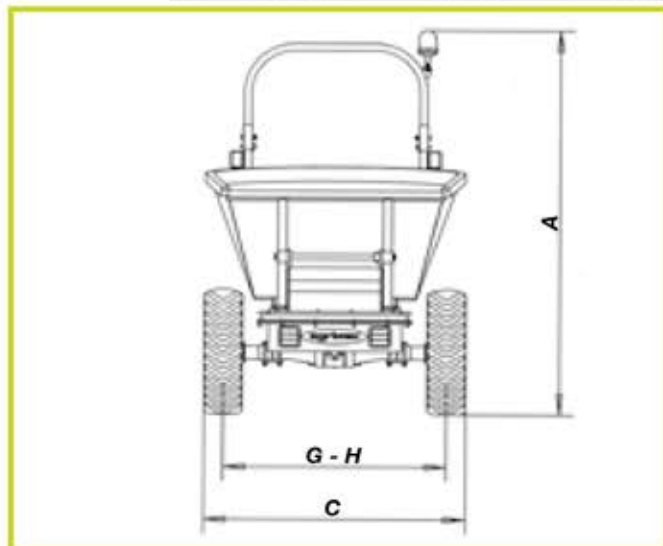
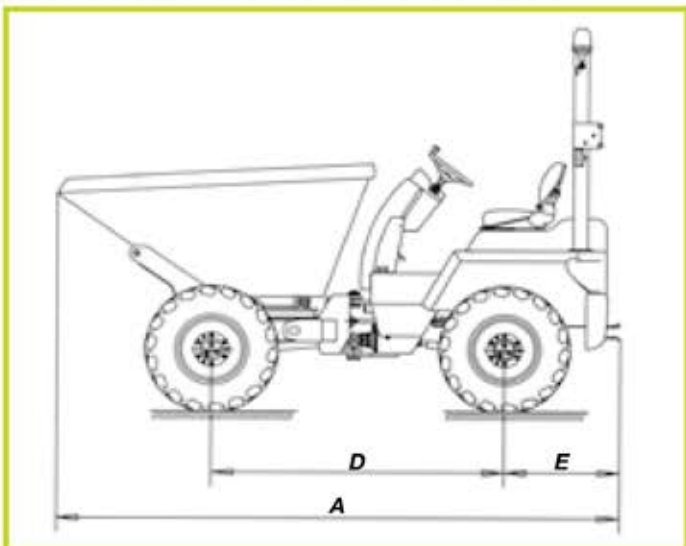

• DH - 350 / 400 AHG • DUMPER

Características Técnicas • Technical Features • Caracteristiques Techniques

	DH - 350 AHG	DH - 400 AHG
 CARGA ÚTIL	Tolva con sistema de descarga giratoria a 180°, 3.500 Kg.	Tolva con sistema de descarga giratoria a 180°. 4.000 Kg.
NIVEL AGUA	1.100 L	1.300 L
COLMADA	2,20 m ³	2,5 m ³
PENDIENTE MAX.	42 %	42 %
MOTOR	Diesel Perkins 4 Cilindros. 37,3 KW (50 CV). Refrigerado por agua	Diesel Perkins 4 cilindros. 37,3 KW (50 CV). Refrigerado por agua
TRANSMISIÓN	Hidrostática REXROTH.	Hidrostática REXROTH con bomba de caudal variable
VELOCIDADES	Lenta: 0 - 9 Km/h • Rápida: 0 - 20 Km/h	Regulación automática de velocidades: 0 a 20 Km.
DIRECCIÓN	Vehículo articulado, dirección hidrostática con válvula de prioridad.	Vehículo articulado, dirección hidrostática con válvula de prioridad.
NEUMÁTICOS	11.5/80-15 (14 PR)	12.0 / 75-18 (12 PR)
FRENOS	De servicio sobre el eje trasero De estacionamiento sobre el eje trasero	De servicio sobre el eje trasero De estacionamiento sobre el eje trasero
PESO	2.410 Kgs.	2500 Kgs.

	DH - 350 AHG	DH - 400 AHG
 USEFUL LOAD	Hopper with lateral 180° Discharge, 3.500 Kg	Hopper with lateral 180° Discharge, 4.000 Kg
WATER LEVEL	1.100 L	1.300 L
FULL TO THE BRIM	2,20 m ³	2,5 m ³
MAX. GRADABILITY	42%	42%
ENGINE	Diesel perkins 4 Cylinders. 37,3 KW (50 HP). Water cooled	Diesel perkins 4 Cylinders. 50 H.P. Water cooled Hydrostatic REXROTH with variable flow pump
TRANSMISSION	Hydrostatic REXROTH.	Progressive automatic speed travel: 0 to 20 Km.
SPEEDS	Slow: 0 - 9 Km/h • High: 0 - 20 Km/h	Articulated vehicle, with hydrostatic steering and priority valve
STEERING	Articulated vehicle, with hydrostatic steering and priority valve	12.0 / 75-18 (12 PR)
WHEELS	11.5 / 80-15 (14 PR)	Service brake on rear axle
BRAKES	Service brake on rear axle parking brake on the rear axle	parking brake on the rear axle
WEIGHT	2.410 Kgs.	2.500 Kgs.

	DH - 350 AHG	DH - 400 AHG
 CHARGE UTILE	Benne avec système de decharge 180°. 3.500 Kg	Benne avec système de decharge 180°. 4.000 Kg
NIVEAU DE EAU	1.100 L	1.300 L
PLEIN	2,20 m ³	2,5 m ³
DECLIVITE MAX	42%	42%
MOTEUR	Diesel Perkins 4 Cylinders. 37,3 KW (50 CV). Per eau	Diesel Perkins 4 Cylindres. 37,3 KW (50 CV). Per eau
TRANSMISSION	Hydrostatique REXROTH.	Hydrostatic REXROTH avec débit variable
VITESSES	Lente: 0 - 9 Km/h • Rapide: 0 - 20 Km/h	Regulation automatique de vitesses: 0 à 20 Km.
DIRECTION	Vehicule articule: direction hydraulique et valve de priorite	Vehicule articule: direction hydraulique et valve de priorite
ROUES	11.5 / 80-15 (14 PR)	12.0 / 75-18 (12 PR)
FREINS	De service: pont arriere, stationnement:pont arriere	De service: pont arriere, stationnement:pont arriere
POIDS	2.410 Kgs.	2.500 Kgs.

Tarifa de Precios • Tariff of Prices • Tarif de Prix

REF:	Descripción • Description • Description
DH - 350 AHG DH - 400 AHG	
MACIZ - DH - 350	Macizado de las 4 ruedas / <i>Wheel fill up</i> / Remplissement des 4 roues
DIP - DH - 350	Diplori / <i>Railway system</i> / Système pour chemin de fer

• **Dumpers hidrostáticos**

• *Hydrostatic dumpers* • *Dumper hydrostatiques*

Modelos • Models • Modèles

• DH - 600 AHG



	DH-600 AHG
A	4.600
B	2.875
C	2.200
D	2.500
E	430
G (Via delantera)	1.800
H (Via trasera)	1.800
Radio Giro Exterior	5,50 m
Radio Giro Interior	3,30 m

Dimensiones • Dimensions • Dimensions

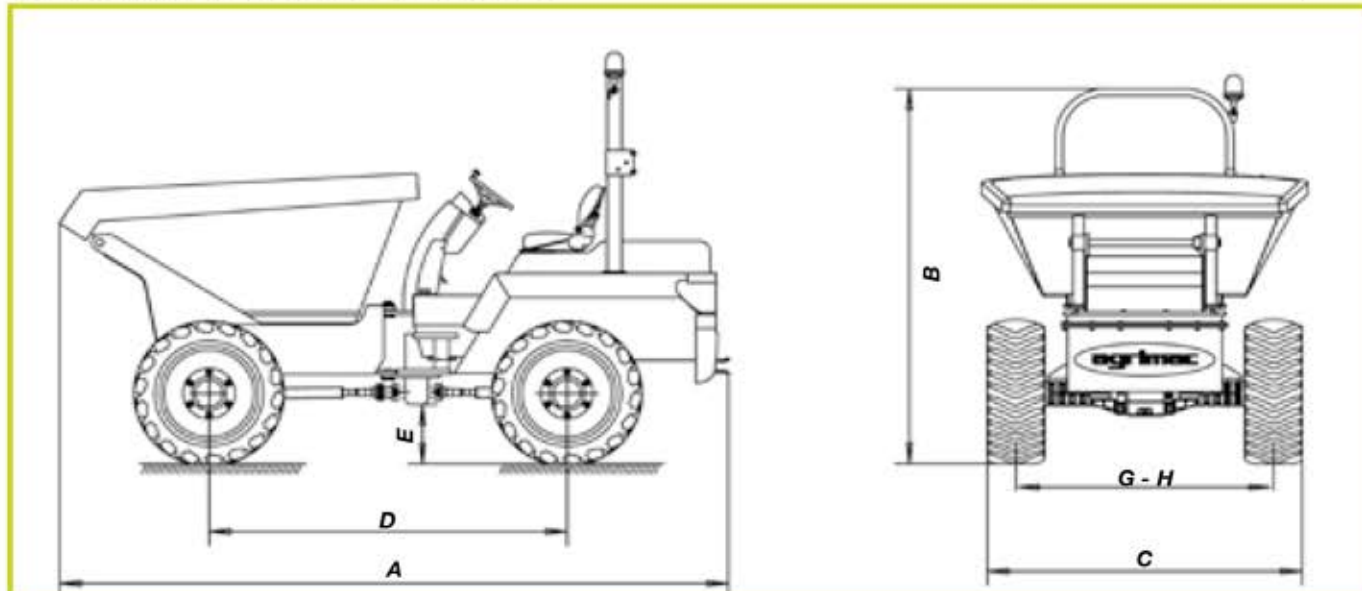

• DH - 600 AHG • DUMPER

Características Técnicas • Technical Features • Caracteristiques Techniques

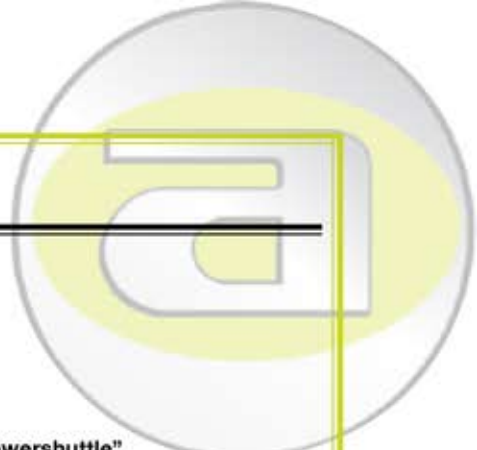

CARGA ÚTIL	Tolva con sistema de descarga giratoria a 180°, 6.000 Kg.
NIVEL AGUA	1.650 L
COLMADA	3,2 m ³
PENDIENTE MAX.	58 %
MOTOR	Diesel perkins 4 Cilindros. 85 CV. Refrigerado por agua
TRANSMISIÓN	Hidrodinámica con convertidor de par, CAT. cambio sincronizado "powershuttle"
VELOCIDADES	4 velocidades desde: 5,2 Km/h a 33,20 Km/h
DIRECCIÓN	Vehículo articulado, dirección hidrostática con 2 cilindros de doble efecto.
NEUMÁTICOS	405 / 70 R 20
FRENOS	Servicio a las 4 ruedas, discos multiples. Estacionamiento: a las ruedas traseras
PESO	4.450 Kgs.



USEFUL LOAD	Hopper with lateral 180° Discharge, 6.000 Kg
WATER LEVEL	1.650 L
FULL TO THE BRIM	3,2 m ³
MAX. GRADABILITY	58%
ENGINE	Diesel Perkins 4 Cylinders. 85 H.P. Water cooled
TRANSMISSION	Hidrodinamic with CAT. par, converter and synchronized change "powershuttle"
SPEEDS	Progressive automatic speed travel: 4 speed range from 5,2 Km/h to 33,20 Km/h
STEERING	Articulated vehicle, with hidrostatic steering and priority valve
WHEELS	405 / 70 R 20
BRAKES	Service Brake: Multiple disc on rear wheels. Parking Brake on the rear axle
WEIGHT	4.450 Kgs.



CHARGE UTILE	Benne avec système de decharge 180°. 6.000 Kg
NIVEAU DE EAU	1.650 L
PLEIN	3,2 m ³
DECLIVITE MAX	58%
MOTEUR	Diesel Perkins 4 Cylindres. 85 H.P. Per eau
TRANSMISSION	Hidrodinamic avec par converter CAT. et synchro "powershuttle"
VITESSES	Regulation automatique de vitesses avec 4 vitesses 5,2 Km/h a 33,20 Km/h
DIRECTION	Vehicule articule: direction hydraulique et valve de priorite
ROUES	405 / 70 R 20
FREINS	De service: Multiple disques sur les arrières roues. Stationnement: Pont arriere
POIDS	4.450 Kgs.

Tarifa de Precios • Tariff of Prices • Tarif de Prix

REF:	Descripción • Description • Description
DH - 600	
MACIZ - DH - 600	Macizado de las 4 ruedas / Wheel fill up / Remplissement des 4 roues
DIP - DH - 600	Diplori / Railway system / Système pour chemin de fer

• **Carretillas elevadoras**
 • **Forklifts** • **Chariots elevateurs**

Modelos • Models • Modèles

• TH - 160



Dimensiones • *Dimensions* • *Dimensions*

G = 1.600 Kg.

1.465
 1.330
 1.200
 1.100
 1.040

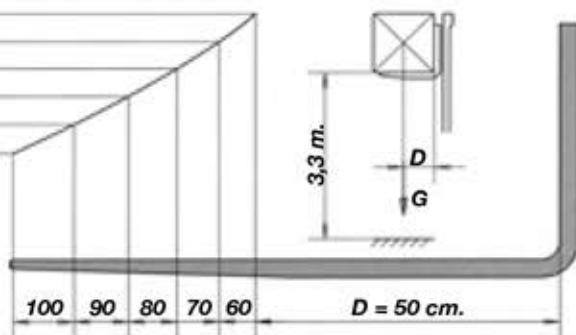

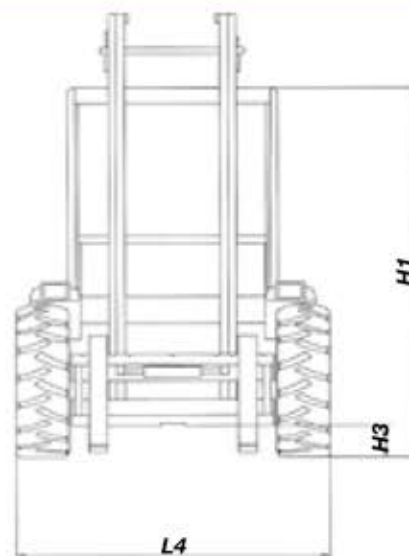
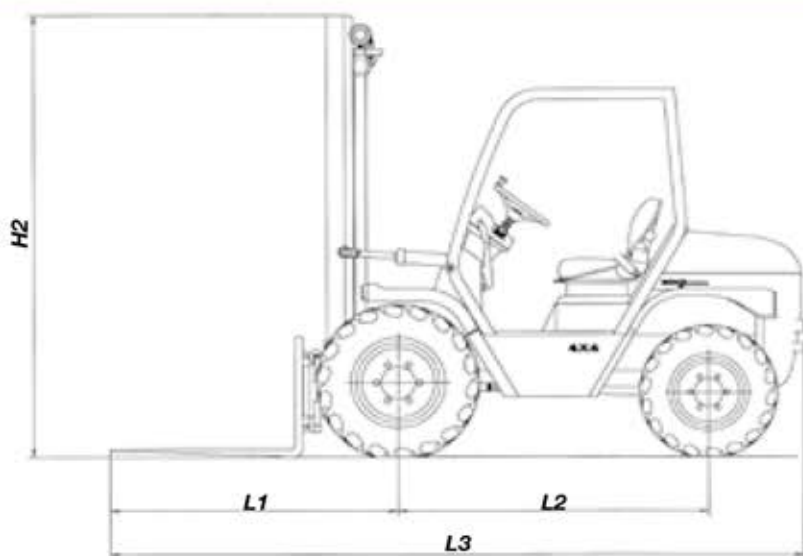

TH - 160	
H1	2.030
H2	Duplex 2,50 m.: 1.950
	Duplex 3,14 m.: 2.250
	Duplex 3,60 m.: 2.480
	Triples 4 m.: 2.050
	Triples 6 m.: 2.820
H3	200
L1	1.545
L2	1600
L3	3.480
L4	1.600



• TH - 160 • Carretillas elevadoras • Forklifts • Chariots elevateurs

Características Técnicas • Technical Features • Caracteristiques Techniques

	MOTOR	Perkins 3 cilindros, Refrigerado por agua, 32 C.V.
	CAPACIDAD Kg.	1.600
	TRANSMISIÓN	Hidrostática Rexroth
	TRACCIÓN	4 x 4 con desconector electrohidráulico con embrague
	VELOCIDAD	Lenta y rápida: desde 0 hasta 21 Km/h. Sistema de aproximación lenta
	FRENOS	Hidrostático a las 4 ruedas, De servicio a las ruedas delanteras, de estacionamiento a las ruedas delanteras
	RUEDAS	10,5/75-15,3 y 8,0/75-15,3
	PESO Kg.	2.950
	PENDIENTE SUP.	38 %
	OPCIONES MÁSTIL m.	Dúplex - Triplex
	RADIO DE GIRO mm.	Exterior: 4.820 / Interior: 2.535

	MOTOR	Perkins 3 cylinders, Water cooled, 32 C.V.
	CAPACITY Kg.	1.600
	TRANSMISSION	Hydrostatic Rexroth
	TRACCIÓN	4 x 4 with electrohydraulic clutch disconnection
	SPEEDS	Slow and fast: 0 - 21 Km/h, Inching Pedal.
	BRAKES	Hydrostatic for 4 wheels, Service Brakes: Acting front wheels. Parking: Mechanic on front axle
	WHEELS	10,5/75-15,3 and 8,0/75-15,3
	WEIGHT Kg.	2.950
	SURMONTABLE SLOPE	38 %
	OPTIONS MAST m.	Dúplex - Triplex
	TURNING RADIUS mm.	External: 4.820 / Internal: 2.535

	MOTEUR	Perkins 3 cylinders , Refroidissement par eau, 32 C.V.
	CAPACITÉ Kg.	1.600
	TRANSMISSION	Hydrostatique Rexroth
	TRACTION	4 x4 avec déconnectateur electrohydraulique pour embrayage
	VITESSES	Lent et rapid: 0 - 21 Km/h, Système approche lente
	FREINS	Hydrostatic a les 4 roues, Frein de Service: Sur le front roues Frein de stationnement: Sur l'arbre de transmission pont avant.
	ROUES	10,5/75-15,3 et 8,0/75-15,3
	POIDS Kg.	2.950
	INCLINATION SURMONTABLE	38 %
	OPTIONS MÂT m	Dúplex - Triplex
	RAYON DE BRACAGE mm.	Exterieur: 4.820 / Interieur: 2.535

Tarifa de Precios • Tariff of Prices • Tarif de Prix

REF:	Descripción • Description • Description
TH - 160	Mástil Dúplex / Duplex Mast / Mât Duplex • 2,50 m. Mástil Dúplex / Duplex Mast / Mât Duplex • 3,14 m. Mástil Dúplex / Duplex Mast / Mât Duplex • 3,60 m. Mástil Tríplex / Triplex Mast / Mât Triplex • 4,00 m. Mástil Tríplex / Triplex Mast / Mât Triplex • 6,00 m.
P - 400	Cuchara para áridos 400 lts. / bucket for arids 400 l. / Pelle pour arides 400 l.
Kit - 4 VAL	• 4ª Toma hidráulica auxiliar / 4th hydraulic auxiliar outlet / 4^{ème} prise hydraulique auxiliaire
MACIZ - TH - 160	Macizado de las 4 ruedas / Wheel fill up / Remplissement des 4 roues
ACRIST - CB	Cristal delantero con limpia parabrisas y cristal techo Front windscreen with windscreen cleaner and roof glass Glace avant avec pare-brise et glace du toit
C - 1500	Cabina / Cabin / Cabine • Calefacción / Heater / Chauffage • Aire acondicionado / Air conditioning / Air conditioné

• **Carretillas elevadoras**
 • **Forklifts** • **Chariots elevateurs**

Modelos • Models • Modèles

• TH - 175 C



Dimensiones • *Dimensions* • *Dimensions*

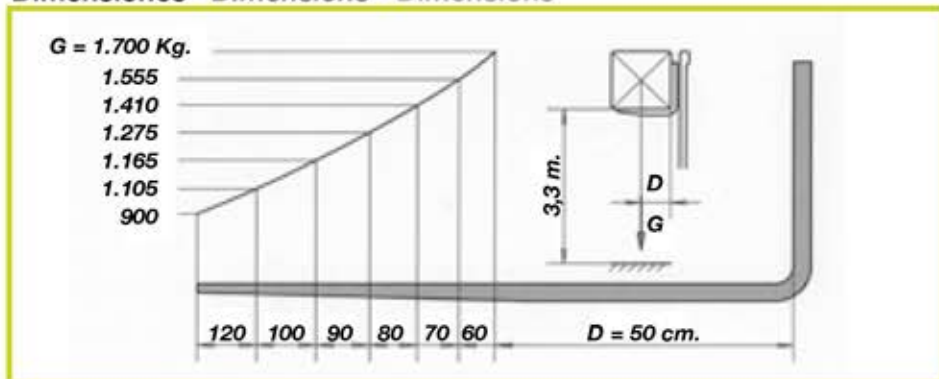

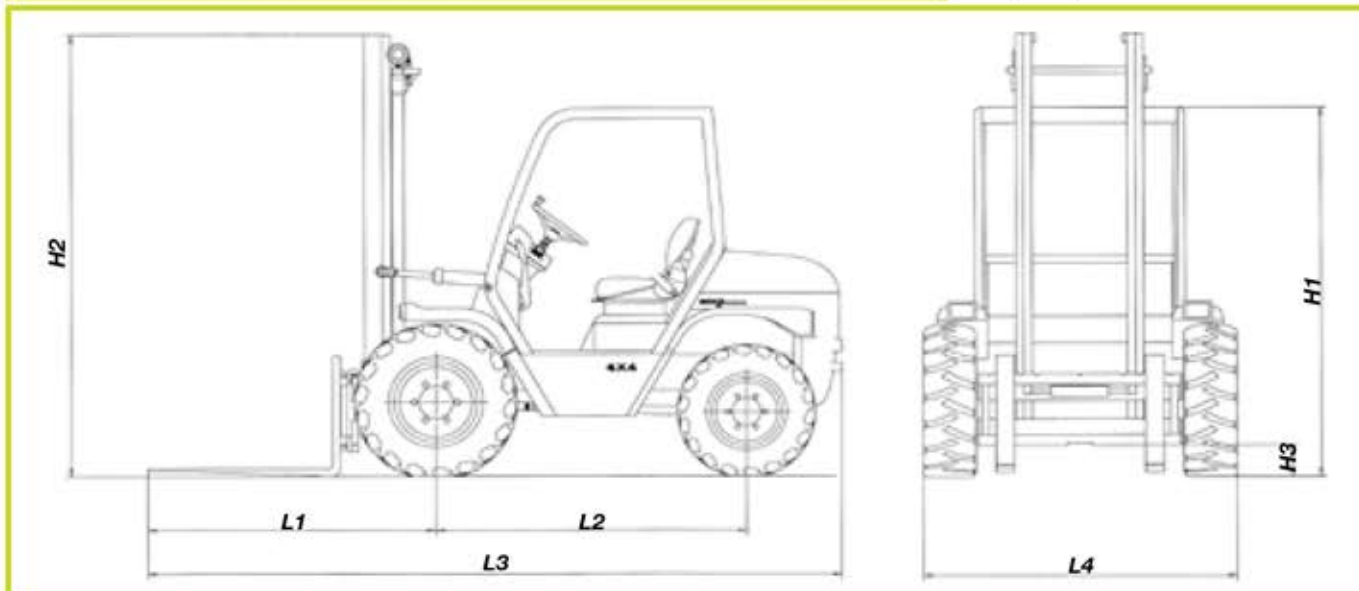

TH - 175 C	
H1	2.065
H2	Dúplex 2,50 m.: 1.950
	Dúplex 3,14 m.: 2.250
	Dúplex 3,60 m.: 2.480
	Triplex 4 m.: 2.050
	Triplex 6 m.: 2.820
H3	200
L1	1.760
L2	1600
L3	3.950
L4	1.300 - 1.400



• TH - 175 C • Carretillas elevadoras • Forklifts • Chariots elevateurs

Características Técnicas • Technical Features • Caracteristiques Techniques

	MOTOR	Perkins 4 cilindros, Refrigerado por agua, 43 C.V.
	CAPACIDAD Kg.	1.700
	TRANSMISIÓN	Hidrostática Rexroth.
	TRACCIÓN	4 x 4 con desconector electrohidraulico.
	VELOCIDAD	Lenta y rápida: desde 0 hasta 22 Km/h. Sistema de aproximación lenta.
	FRENOS	Hidrostático a las 4 ruedas, De servicio a las ruedas delanteras, de estacionamiento a las ruedas delanteras.
	RUEDAS	10,0 / 75 - 15,3 y 6,50 - 16
	PESO Kg.	2.735
	PENDIENTE SUP.	38 %
	OPCIONES MÁSTIL m.	Dúplex - Triplex

	MOTOR	Perkins 4 cylinders, Water cooled, 43 C.V.
	CAPACITY Kg.	1.700
	TRANSMISSION	Hydrostatic Rexroth.
	TRACCIÓN	4 x 4 with electrohydraulic disconnection.
	SPEEDS	Slow and fast: 0 - 22 Km/h, Inching Pedal.
	BRAKES	Hydrostatic for 4 wheels, Service Brakes: Acting front wheels. Parking: Mechanic on front axle.
	WHEELS	10,0 / 75 - 15,3 and 6,50 - 16.
	WEIGHT Kg.	2.735
	SURMONTABLE SLOPE	38 %
	OPTIONS MAST m.	Dúplex - Triplex.

	MOTEUR	Perkins 4 cylinders , Refroidissement par eau, 43 C.V.
	CAPACITÉ Kg.	1.700
	TRANSMISSION	Hydrostatique Rexroth.
	TRACTION	4 x4 avec déconnectateur electrohydraulique.
	VITESSES	Lent et rapid: 0 - 22 Km/h, Système approche lente.
	FREINS	Hydrostatic a les 4 roues, Frein de Service: Sur le front roues Frein de stationnement: Sur l'arbre de transmission pont avant.
	ROUES	10,0 / 75 - 15,3 et 6,50 - 16
	POIDS Kg.	2.735
	INCLINATION SURMONTABLE	38 %
	OPTIONS MÂT m	Dúplex - Triplex

Tarifa de Precios • Tariff of Prices • Tarif de Prix

REF:	Descripción • Description • Description
TH - 175 C	Mástil Dúplex / Duplex Mast / Mât Duplex • 2,50 m. Mástil Dúplex / Duplex Mast / Mât Duplex • 3,14 m. Mástil Dúplex / Duplex Mast / Mât Duplex • 3,60 m. Mástil Triplex / Triplex Mast / Mât Triplex • 4,00 m. Mástil Triplex / Triplex Mast / Mât Triplex • 6,00 m.
P - 400	Cuchara para áridos 400 lts. / bucket for arids 400 l. / Pelle pour arides 400 l. • 4ª Toma hidráulica auxiliar / 4 th hydraulic auxiliar outlet / 4 ^{ème} prise hydraulique auxiliaire
MACIZ - TH - 175	Macizado de las 4 ruedas / Wheel fill up / Remplissement des 4 roues
ACRIST - CB	Cristal delantero con limpia parabrisas y cristal techo Front windscreen with windscreen cleaner and roof glass Glace avant avec pare-brise et glace du toit
C - 1500	Cabina / Cabin / Cabine • Calefacción / Heater / Chauffage • Aire acondicionado / Air conditioning / Air conditioné

• Carretillas elevadoras

• Forklifts • Chariots elevateurs

Modelos • Models • Modèles

• TH - 210



Dimensiones • Dimensions • Dimensions

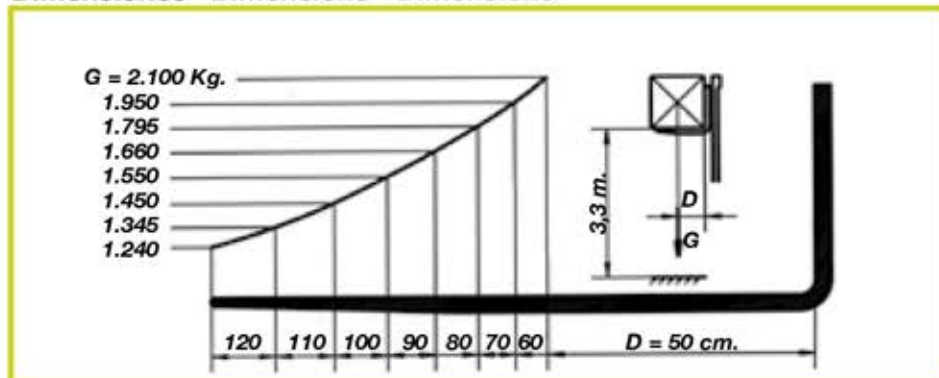

TH - 210	
H1	2.080
H2	Dúplex 3,14 m.: 2.250
	Dúplex 3,60 m.: 2.510
	Triples 4 m.: 2.080 Triples 6 m.: 2.850
H3	200
L1	1.480
L2	1.700
L3	3.800
L4	1.700

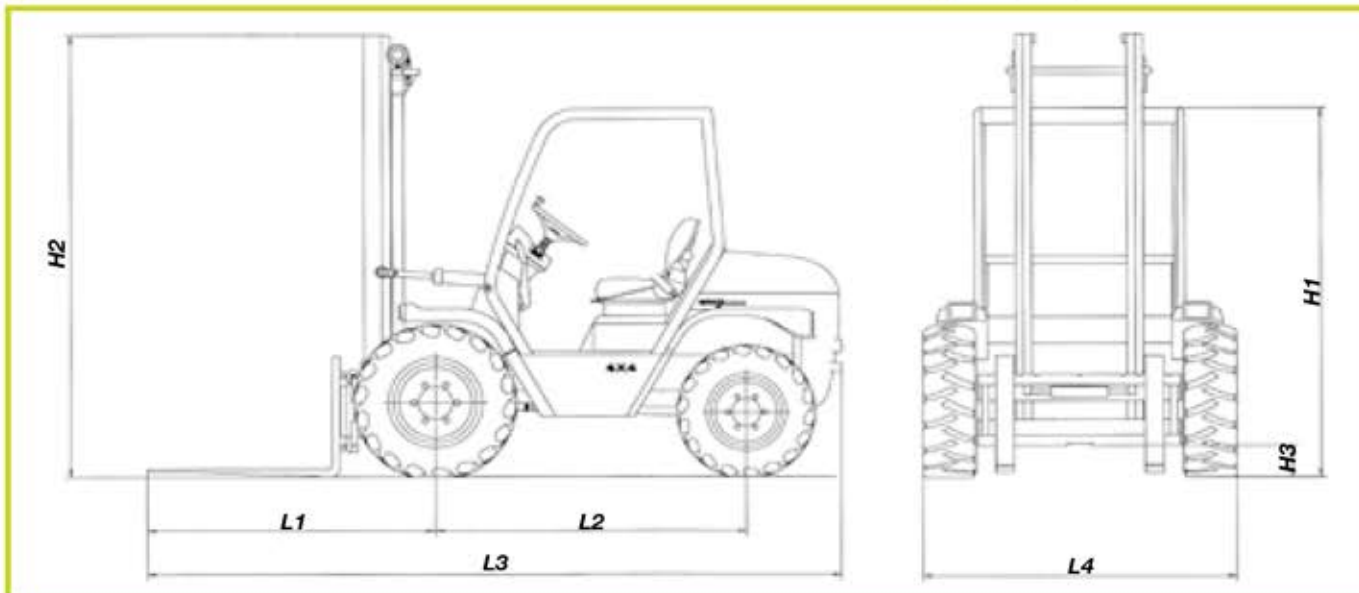

• TH - 210 • Carretillas elevadoras • Forklifts • Chariots elevateurs

Características Técnicas • Technical Features • Caracteristiques Techniques



MOTOR	Perkins 4 cilindros, Refrigerado por agua, 43 C.V.
CAPACIDAD Kg.	2.100
TRANSMISIÓN	Hidrostática Rexroth.
TRACCIÓN	4 x 4 con desconector electrohidraulico con embrague.
VELOCIDAD	Lenta y rápida: desde 0 hasta 22 km/h. Sistema de aproximación lenta.
FRENOS	Hidrostático a las 4 ruedas, De servicio a las ruedas delanteras, de estacionamiento a las ruedas delanteras.
RUEDAS	11,50/80-15,3 y 10,0/75-15,3
PESO Kg.	3.350
PENDIENTE SUP.	38 %
OPCIONES MÁSTIL m.	Dúplex - Tríplex
RADIO DE GIRO mm.	Exterior: 4.450 / Interior: 2.950



MOTOR	Perkins 4 cylinders, Water cooled, 43 C.V.
CAPACITY Kg.	2.100
TRANSMISSION	Hydrostatic Rexroth.
TRACCIÓN	4 x 4 with electrohydraulic disconnection.
SPEEDS	Slow and fast: 0 - 22 Km/h, Inching Pedal slow approaching system.
BRAKES	Hydrostatic for 4 wheels, Service Brakes: Acting front wheels. Parking: Mechanic on front axle.
WHEELS	11,50/80-15,3 and 10,0/75-15,3
WEIGHT Kg.	3.350
SURMONTABLE SLOPE	38 %
OPTIONS MAST m.	Dúplex - Triplex.
TURNING RADIUS mm.	External: 4.450 / Internal: 2.950



MOTEUR	Deutz 4 cylinders , Refroidissement par eau, 43 C.V.
CAPACITÉ Kg.	2.100
TRANSMISSION	Hydrostatique Rexroth.
TRACTION	4 x4 avec déconnectateur electrohydraulique avec embrayage.
VITESSES	Lent et rapid: 0 - 24 Km/h, Système approche lente.
FREINS	Hydrostatic a les 4 roues, Frein de Service: Sur le front roues Frein de stationnement: Sur l'arbre de transmission pont avant.
ROUES	11,50/80-15,3 et 10,0/75-15,3
POIDS Kg.	3.350
INCLINATION SURMONTABLE	38 %
OPTIONS MÂT m.	Dúplex - Triplex
RAYON DE BRACAGE mm.	Exterieur: 4.450 / Interieur: 2.950

Tarifa de Precios • Tariff of Prices • Tarif de Prix

REF:	Descripción • Description • Description
TH - 210	Mástil Dúplex / Duplex Mast / Mât Duplex • 3,14 m. Mástil Dúplex / Duplex Mast / Mât Duplex • 3,60 m. Mástil Tríplex / Triplex Mast / Mât Triplex • 4,00 m. Mástil Tríplex / Triplex Mast / Mât Triplex • 6,00 m.
P - 400	Cuchara para áridos 400 lts. / bucket for arids 400 l. / Pelle pour arides 400 l.
Kit - 4 VAL	• 4ª Toma hidráulica auxiliar / 4th hydraulic auxiliar outlet / 4^{ème} prise hydraulique auxiliaire
MACIZ - TH - 210	Macizado de las 4 ruedas / Wheel fill up / Remplissement des 4 roues
ACRIST - CB	Cristal delantero con limpia parabrisas y cristal techo Front windscreen with windscreen cleaner and roof glass Glace avant avec pare-brise et glace du toit
C - 1500	Cabina / Cabin / Cabine • Calefacción / Heater / Chauffage • Aire acondicionado / Air conditioning / Air conditioné

• **Carretillas elevadoras**
 • **Forklifts** • **Chariots elevateurs**

Modelos • *Models* • *Modèles*

• TH - 250



Dimensiones • *Dimensions* • *Dimensions*

G = 2.500 Kg.

- 2.320
- 2.165
- 2.030
- 1.910
- 1.800
- 1.705
- 1.620

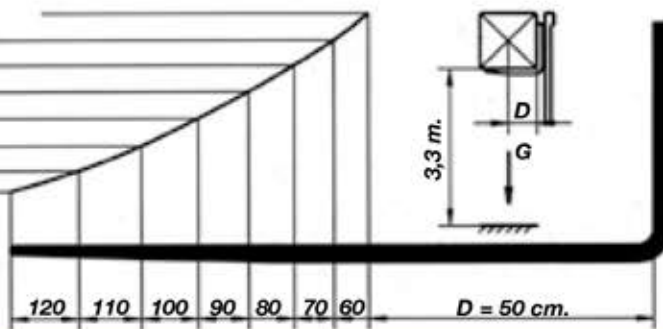

TH - 250	
H1	2.290
H2	Dúplex 3,60 m.: 2.510 Triplex 4,50 m.: 2.290 Triplex 5 m.: 2.500 Triplex 6 m.: 2.850
H3	200
L1	1.765
L2	1.800
L3	4.200
L4	1.800

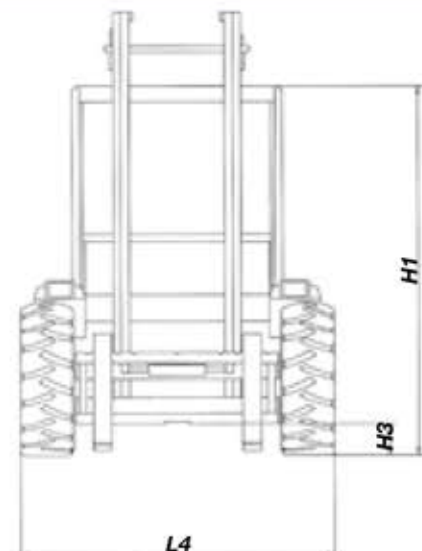
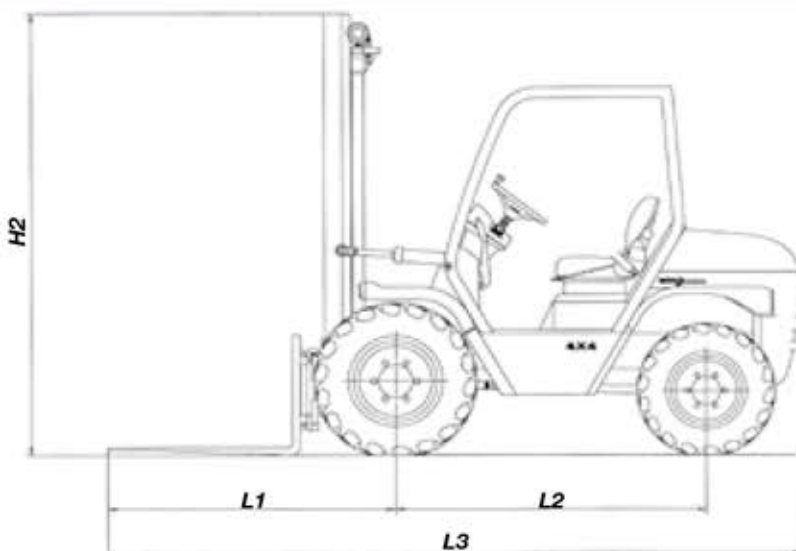

• TH - 250 • Carretillas elevadoras • Forklifts • Chariots elevateurs

Características Técnicas • Technical Features • Caracteristiques Techniques



MOTOR	Deutz 4 cilindros, Refrigerado por aire, 60 C.V.
CAPACIDAD Kg.	2.500
TRANSMISIÓN	Hidrostática Rexroth.
TRACCIÓN	4 x 4 con desconectador electrohidraulico.
VELOCIDAD	24 Km/h. Sistema de aproximación lenta.
FRENOS	Hidrostático a las 4 ruedas, De servicio a las ruedas delanteras, de estacionamiento a las ruedas delanteras.
RUEDAS	11,50/80-15,3
PESO Kg.	3.950
PENDIENTE SUP.	38 %
OPCIONES MÁSTIL m.	Dúplex - Triplex
OPCIONES CABINA	Cabina baja a 2.100 mm. de altura máxima con triplex 4,00 mts.
RADIO DE GIRO mm.	Exterior: 4.150 / Interior: 1.750



MOTOR	Deutz 4 cylinders, Air cooled, 60 C.V.
CAPACITY Kg.	2.500
TRANSMISSION	Hydrostatic Rexroth with variable flow.
TRACCIÓN	4 x 4 with electrohydraulic disconnection.
SPEEDS	Slow and fast: 0 - 24 Km/h, Inching Pedal.
BRAKES	Hydrostatic for 4 wheels, Service Brakes: Acting front wheels. Parking: Mechanic on front axle.
WHEELS	11,50/80-15,3.
WEIGHT Kg.	3.950
SURMONTABLE SLOPE	38 %
OPTIONS MAST m.	Dúplex - Triplex.
CABIN OPTIONS	Low profile cabin with a maximum height 2.100 mm. with Triplex 4,00 mts.
TURNING RADIUS mm.	External: 4.150 / Internal: 1.750



MOTEUR	Deutz 4 cylinders, Refroidissement par air, 60 C.V.
CAPACITÉ Kg.	2.500
TRANSMISSION	Hydrostatique Rexroth avec débit variable.
TRACTION	4 x4 avec déconnectateur electrohydraulique.
VITESSES	Lent et rapid: 0 - 24 Km/h, Système approche lente.
FREINS	Hydrostatic a les 4 roues, Frein de Service: Sur le front roues Frein de stationnement: Sur l'arbre de transmission pont avant.
ROUES	11,50/80-15,3
POIDS Kg.	3.950
INCLINATION SURMONTABLE	38 %
OPTIONS MÂT m	Dúplex - Triplex
OPTIONS CABIN	Cabin basse a 2.100 mm. d'hauteur. Avec Triplex mât 4,00 mts
RAYON DE BRACAGE mm.	Exterieur: 4.150 / Interieur: 1.750

Tarifa de Precios • Tariff of Prices • Tarif de Prix

REF:	Descripción • Description • Description
TH - 250	Mastil Duplex / Duplex Mast / Mât Duplex • 3,60 m. Mastil Triplex / Triplex Mast / Mât Triplex • 4,50 m. Mastil Triplex / Triplex Mast / Mât Triplex • 5,00 m. Mastil Triplex / Triplex Mast / Mât Triplex • 6,00 m.
TH - 250 B	Cabina baja, Triplex 4,00 / Low profile, Triplex 4,00 / Cabin basse, Triplex 4,00
P - 500	Cuchara para áridos 500 lts. / bucket for arids 500 l. / Pelle pour arides 500 l. • 4ª Toma hidráulica auxiliar / 4ª hydraulic auxiliar outlet / 4^{ème} prise hydraulique auxiliaire
MACIZ - TH - 250	Macizado de las 4 ruedas / Wheel fill up / Remplissement des 4 roues
ACRIST - CA	Cristal delantero con limpia parabrisas y cristal techo Front windscreen with windscreen cleaner and roof glass Glase avant avec pare-brise et glase du toit
C - 3000	Cabina / Cabin / Cabine • Calefacción / Heater / Chauffage • Aire acondicionado / Air conditioning / Air conditioné

• **Carretillas elevadoras**
 • **Forklifts** • **Chariots elevateurs**

Modelos • Models • Modèles

• TH - 300



Dimensiones • *Dimensions* • *Dimensions*

G = 3.000 Kg.

- 2.785
- 2.600
- 2.435
- 2.290
- 2.160
- 2.045
- 1.945

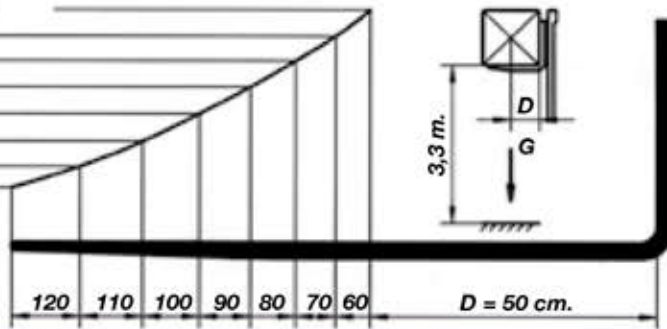

TH - 300	
H1	2.310
H2	Dúplex 3,60 m.: 2.515 Triplex 4,50 m.: 2.295 Triplex 5 m.: 2.505 Triplex 6 m.: 2.855
H3	230
L1	1.765
L2	1.800
L3	4.315
L4	1.948

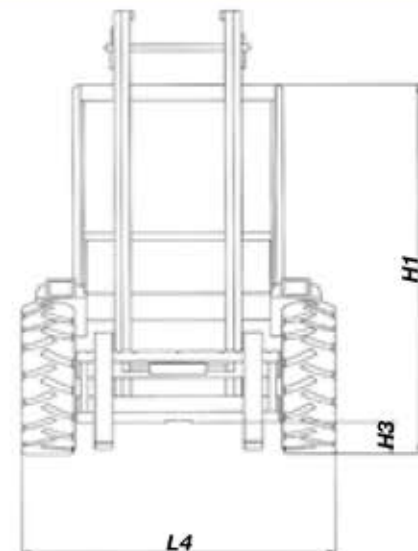
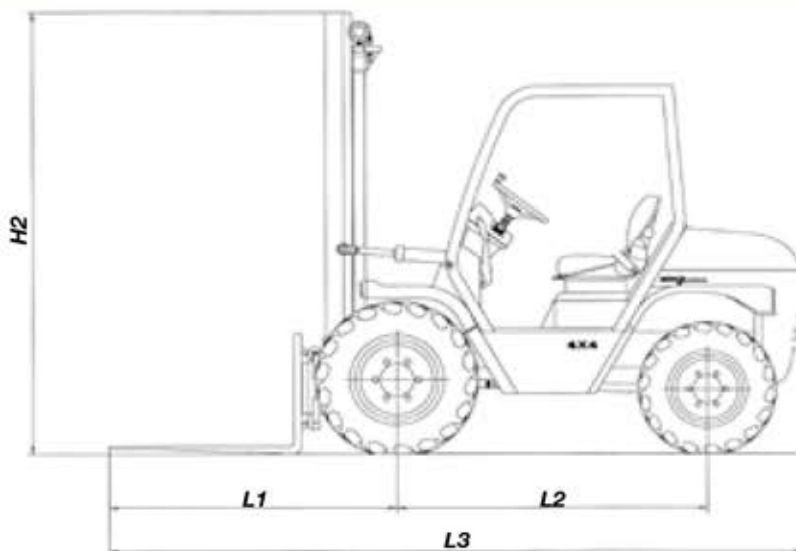

• TH - 300 • Carretillas elevadoras • Forklifts • Chariots elevateurs

Características Técnicas • Technical Features • Caracteristiques Techniques



MOTOR	Deutz 4 cilindros, Refrigerado por aire, 60 C.V.
CAPACIDAD Kg.	3.000
TRANSMISIÓN	Hidrostática Rexroth.
TRACCIÓN	4 x 4 con desconector electrohidraulico.
VELOCIDAD	24 Km/h. Sistema de aproximación lenta.
FRENOS	Hidrostático a las 4 ruedas, De servicio a las ruedas delanteras, de estacionamiento a las ruedas
RUEDAS	delanteras.12,0/75-18
PESO Kg.	4.300
PENDIENTE SUP.	38 %
OPCIONES MÁSTIL m.	Dúplex - Triplex
RADIO DE GIRO mm.	Exterior: 4.250 / Interior: 1.800



MOTOR	Deutz 4 cylinders, Air cooled, 60 C.V.
CAPACITY Kg.	3.000
TRANSMISSION	Hydrostatic Rexroth with variable flow.
TRACCIÓN	4 x 4 with electrohydraulic disconnection.
SPEEDS	Slow and fast: 0 - 24 Km/h, Inching Pedal.
BRAKES	Hydrostatic for 4 wheels, Service Brakes: Acting front wheels.Parking: Mechanic on front axle.
WHEELS	12,0/75-18
WEIGHT Kg.	4.300
SURMONTABLE SLOPE	38 %
OPTIONS MAST m.	Dúplex - Triplex.
TURNING RADIUS mm.	External: 4.250 / Internal: 1.800



MOTEUR	Deutz 4 cylinders , Refroidissement par air, 60 C.V.
CAPACITÉ Kg.	3.000
TRANSMISSION	Hydrostatique Rexroth avec débit variable.
TRACTION	4 x4 avec déconnectateur electrohydraulique.
VITESSES	Lent et rapid: 0 - 24 Km/h, Système approche lente.
FREINS	Hydrostatic a les 4 roues, Frein de Service: Sur le front roues Frein de stationnement: Sur l'arbre de transmission pont avant.
ROUES	12,0/75-18
POIDS Kg.	4.300
INCLINATION SURMONTABLE	38 %
OPTIONS MÂT m.	Dúplex - Triplex
RAYON DE BRACAGE mm.	Exterieur: 4.250 / Interieur: 1.800

Tarifa de Precios • Tariff of Prices • Tarif de Prix

REF:	Descripción • Description • Description
TH - 300	Mástil Dúplex / Duplex Mast / Mât Duplex • 3,60 m. Mástil Triplex / Triplex Mast / Mât Triplex • 4,50 m. Mástil Triplex / Triplex Mast / Mât Triplex • 5,00 m. Mástil Triplex / Triplex Mast / Mât Triplex • 6,00 m.
P - 500	Cuchara para áridos 500 lts. / bucket for arids 500 l. / Pelle pour arides 500 l. • 4ª Toma hidráulica auxiliar / 4ª hydraulic auxiliar outlet / 4ème prise hydraulique auxiliaire
MACIZ - TH - 300	Macizado de las 4 ruedas / Wheel fill up / Remplissement des 4 roues
ACRIST - CA	Cristal delantero con limpia parabrisas y cristal techo Front windscreen with windscreen cleaner and roof glass Glace avant avec pare-brise et glace du toit
C - 3000	Cabina / Cabin / Cabine • Calefacción / Heater / Chauffage • Aire acondicionado / Air conditioning / Air conditioné

• **Carretillas elevadoras**
 • **Forklifts** • **Chariots elevateurs**

Modelos • *Models* • *Modèles*

• TH - 350



Dimensiones • *Dimensions* • *Dimensions*

G = 3.500 Kg.

- 2.785
- 2.600
- 2.435
- 2.290
- 2.160
- 2.045
- 1.945

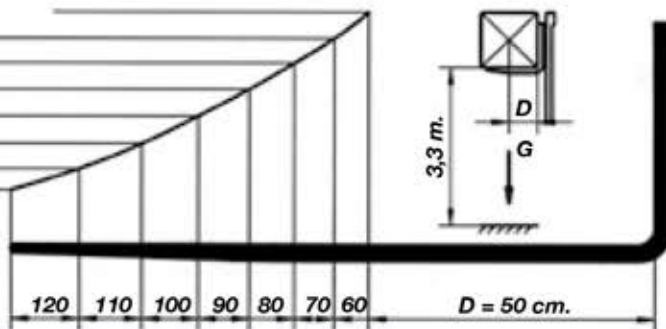

TH - 350	
H1	2.310
H2	Dúplex 3,60 m.: 2.515 Triplex 4,50 m.: 2.295 Triplex 5 m.: 2.505 Triplex 6 m.: 2.855
H3	230
L1	1.765
L2	1.800
L3	4.315
L4	1.948

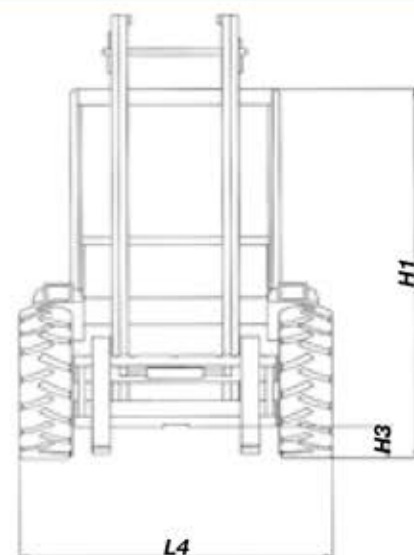
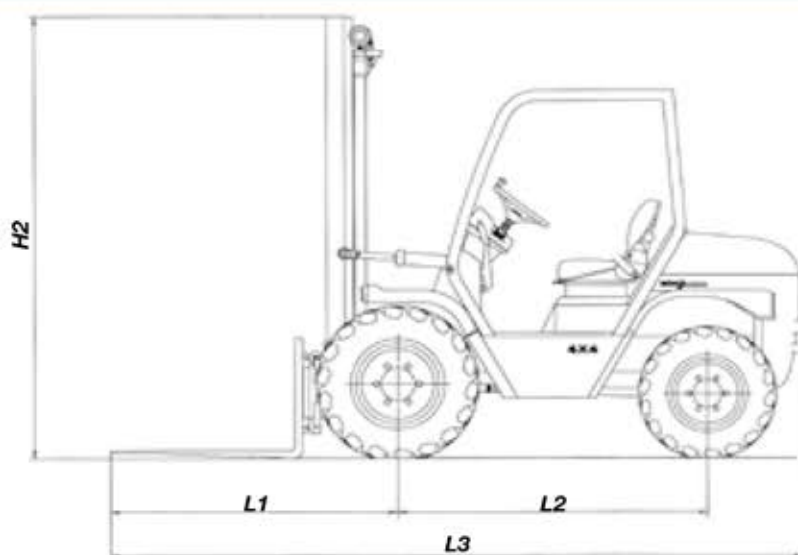

• TH - 350 • Carretillas elevadoras • Forklifts • Chariots elevateurs

Características Técnicas • Technical Features • Caracteristiques Techniques



MOTOR	Deutz 4 cilindros, Refrigerado por aire, 60 C.V.
CAPACIDAD Kg.	3.500
TRANSMISIÓN	Hidrostática Rexroth.
TRACCIÓN	4 x 4 con desconectador electrohidraulico.
VELOCIDAD	24 Km/h. Sistema de aproximación lenta.
FRENOS	Hidrostático a las 4 ruedas, De servicio a las ruedas delanteras, de estacionamiento a las ruedas
RUEDAS	delanteras.12,0/75-18
PESO Kg.	4.500
PENDIENTE SUP.	38 %
OPCIONES MÁSTIL m.	Dúplex - Triplex
RADIO DE GIRO mm.	Exterior: 4.150 / Interior: 1.750



MOTOR	Deutz 4 cylinders, Air cooled, 60 C.V.
CAPACITY Kg.	3.500
TRANSMISSION	Hydrostatic Rexroth with variable flow.
TRACCIÓN	4 x 4 with electrohydraulic disconnection.
SPEEDS	Slow and fast: 0 - 24 Km/h, Inching Pedal.
BRAKES	Hydrostatic for 4 wheels, Service Brakes: Acting front wheels.Parking: Mechanic on front axle.
WHEELS	12,0/75-18
WEIGHT Kg.	4.500
SURMONTABLE SLOPE	38 %
OPTIONS MAST m.	Dúplex - Triplex.
TURNING RADIUS mm.	External: 4.150 / Internal: 1.750



MOTEUR	Deutz 4 cylinders , Refroidissement par air, 60 C.V.
CAPACITÉ Kg.	3.500
TRANSMISSION	Hydrostatique Rexroth avec débit variable.
TRACTION	4 x4 avec déconnectateur electrohydraulique.
VITESSES	Lent et rapid: 0 - 24 Km/h, Système approche lente.
FREINS	Hydrostatic a les 4 roues, Frein de Service: Sur le front roues Frein de stationnement: Sur l'arbre de transmission pont avant.
ROUES	12,0/75-18
POIDS Kg.	4.500
INCLINATION SURMONTABLE	38 %
OPTIONS MÂT m.	Dúplex - Triplex
RAYON DE BRACAGE mm.	Exterieur: 4.150 / Interieur: 1.750

Tarifa de Precios • Tariff of Prices • Tarif de Prix

REF:	Descripción • Description • Description
TH - 350	Mástil Dúplex / Duplex Mast / Mât Duplex • 3,60 m. Mástil Triplex / Triplex Mast / Mât Triplex • 4,50 m. Mástil Triplex / Triplex Mast / Mât Triplex • 5,00 m. Mástil Triplex / Triplex Mast / Mât Triplex • 6,00 m.
P - 500	Cuchara para áridos 500 lts. / bucket for arids 500 l. / Pelle pour arides 500 l. • 4ª Toma hidráulica auxiliar / 4 th hydraulic auxiliar outlet / 4 ^{ème} prise hydraulique auxiliaire
MACIZ - TH - 300	Macizado de las 4 ruedas / Wheel fill up / Remplissement des 4 roues
ACRIST - CA	Cristal delantero con limpia parabrisas y cristal techo Front windscreen with windscreen cleaner and roof glass Glace avant avec pare-brise et glace du toit
C - 3000	Cabina / Cabin / Cabine • Calefacción / Heater / Chauffage • Aire acondicionado / Air conditioning / Air conditioné

Pala Cargadora • Wheel loader • Pelle Chargeur

Modelos • Models • Modèles

• P - 650



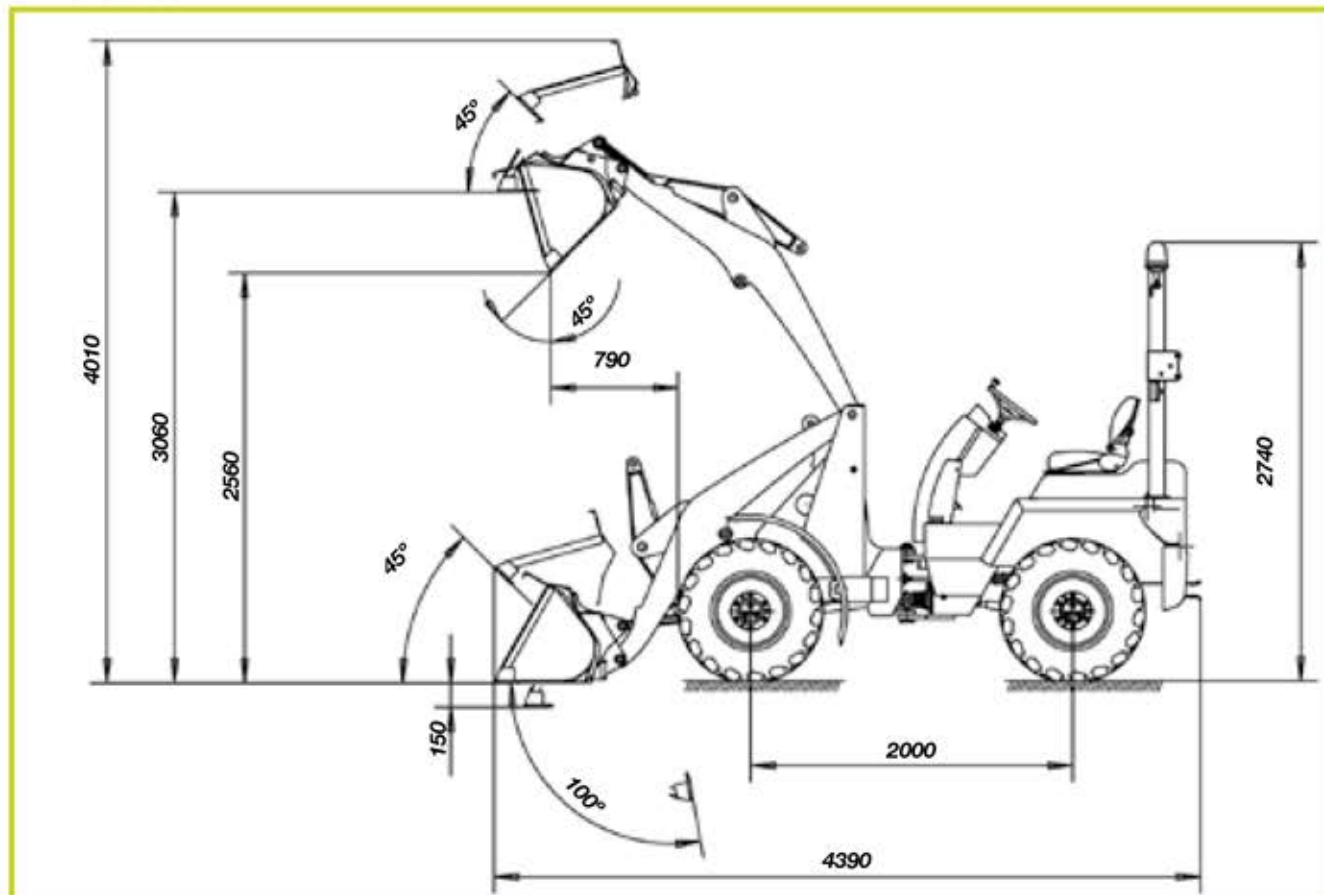

Dimensiones • Dimensions • Dimensions



• P - 650 • Pala Cargadora • Wheel loader • Pelle Chargeur

Características Técnicas • Technical Features • Caracteristiques Techniques

	MOTOR	Perkins 4 cilindros, 52 C.V.
	CAPACIDAD Kg.	Cuchara estándar: 0,65 m ³ . Capacidad de Carga: 1.100 Kg. Depósito de combustible: 50 L.
	TRANSMISIÓN	Hidrostática Rexroth.
	TRACCIÓN	4 x 4 con desconectador.
	VELOCIDAD	0 - 24 Km/h.
	FRENOS	Hidrostático a las 4 ruedas, De servicio a las ruedas delanteras, de estacionamiento a las ruedas.
	RUEDAS	12,0/75-18
	PESO Kg.	En vacío: 3.600 Kg. Peso máximo admisible en carga: 5.000 Kg.
	PENDIENTE SUP.	60 %
	EQUIP. DE SERIE	Cuadro de instrumentos. Equipo de iluminación y señalización, según Regl. Gral. de vehículos. Asiento de suspensión con apoyabrazos y regulables. Cinturón de seguridad. Girofaro. Enganche de remolque tipo BO UNE 68014-87/2. Arco de protección ROPS, abatible según, UNE-EN 13510
	EQUIP. OPCIONAL	Distribuidor de Cuadro correderas para conexión rápida. Techo protector. Cabina. luces de trabajo. Horquilla porta palets. Cuchara de diferentes cubicajes.

	MOTOR	Perkins 4 cylinders, 52 C.V.
	CAPACITY Kg.	Standard bucket: 0,65 m ³ . Load capacity: 1.100 Kg. Fuel tank: 50 L.
	TRANSMISSION	Hydrostatic Rexroth.
	TRACCIÓN	4 x 4 with electrohydraulic disconnection.
	SPEEDS	0 - 24 Km/h.
	BRAKES	Hydrostatic for 4 wheels, Service Brakes: Acting front wheels. Parking: Mechanic on front axle.
	WHEELS	12,0/75-18
	WEIGHT Kg.	Empty: 3.600 Kg. Max. Weigh admisible with load: 5.000 Kg.
	SURMONTABLE SLOPE	60 %
	SERIE EQUIPMENT	Instrument pannel. Lighting and signalization equipment according Vehicules General Regla-ments. Suspension seat with arm lean and regulable. Security seat bealt. Headlight turning. Trailer hitch tyoe BO UNE 68014-87/2. Protection arc ROPS, folding, according UNE-EN 13510.
	OPTIONAL EQUIPMENT	Distributor of four commands for fast connexions. Protecting roof. Cabin. Working lights. Palet forks. Different bucket capacities

	MOTEUR	Perkins 4 cylinders , 52 C.V.
	CAPACITÉ Kg.	Cuillère standard: 0,65 m ³ . Capacité de charge: 1.100 Kg. Tank de fuel: 50 L.
	TRANSMISSION	Hydrostatique Rexroth.
	TRACTION	4 x4 avec déconnectateur electrohydraulique.
	VITESSES	0 - 24 Km/h.
	FREINS	Hydrostatic a les 4 roues, Frein de Service: Sur le front roues Frein de stationnement: Sur l'abre de transmission pont avant.
	ROUES	12,0/75-18
	POIDS Kg.	Vide: 3.600 Kg. Poids max. Admissible avec charge: 5.000 Kg.
	INCLINATION SURMON-	60 %
	TABLE	Tableau d'instrumentes. Lumière et equipe de signalization d'accord a la Reglamentation Générale de Vehicules
	EQUIPEMENT DE SERIE	Siège avec amortisseur et réglables, avec appui bras. Ceinture de sécurité. Feu arrière de travail Attelage arrière type BO UNE 68014-87/2. Arch de protection ROPS, abatible, selon UNE-EN 13510. Distributeur de quatre commandes pour attaché rapide. Toite protecteur. Cabine. Lumières de travail
	EQUIPEMENT OPTIONEL	Fourchéttes. Cuillères de différentes capacités

Tarifa de Precios • Tariff of Prices • Tarif de Prix

REF:	Descripción • Description • Description
P - 650	Pala cargadora / Wheel loader / Pelle Chargeur
POR HORQ. P - 650	Porta Horquillas / Fork Carriage / Porte Fourchette
MACIZ - TH - 300	Macizado de las 4 ruedas / Wheel fill up / Remplissement des 4 roues

Dumper Barredora • Dumper-Sweeper • Dumper-Balayeuse

Modelos • Models • Modèles

• DH - 200 BA



Dimensiones • Dimensions • Dimensions

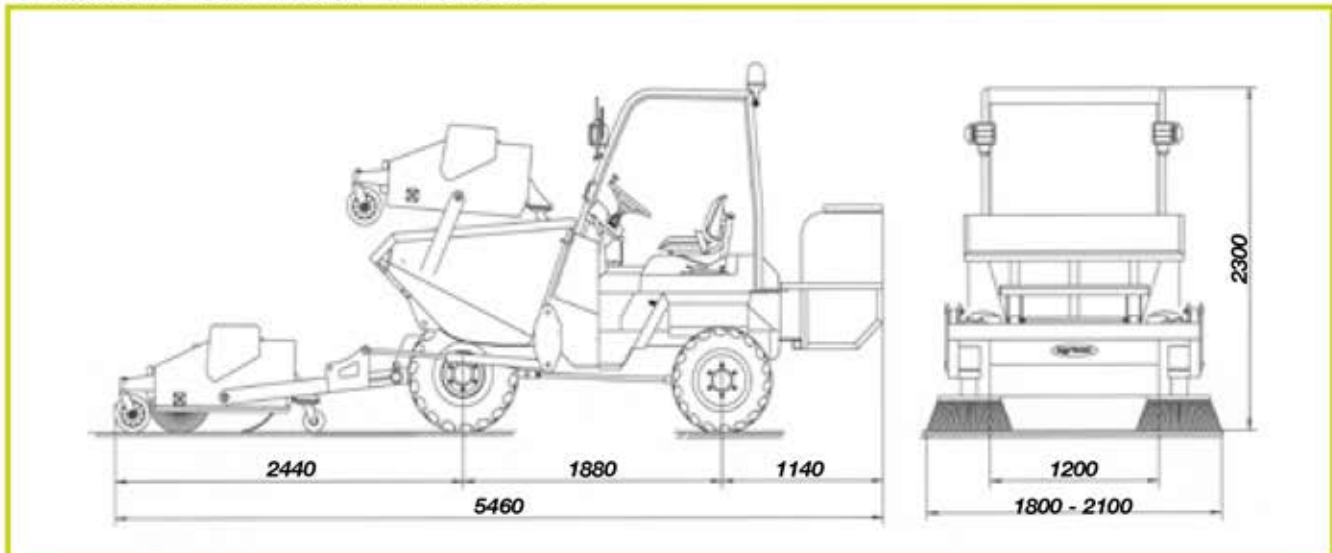

• DH 200 BA • Dumper Barredora • Dumper-Sweeper • Dumper-Balayeuse

Características Técnicas • Technical Features • Caracteristiques Techniques



NIVEL AGUA	835 Ltrs.
COLMADA	1,2 m ³
PENDIENTE MÁXIMA	42%
MOTOR	Diesel Perkins, 3 C. 36 H.P. Refrigerado por agua
TRANSMISIÓN	REXROTH Hidrostática con bomba caudal variable
VELOCIDADES	L/S/L: 0 - 9 Km/h. • R/H/R: 0 - 20 Km/h.
DIRECCIÓN	Hidrostática Puente trasero
NEUMÁTICOS	10.0/75 - 15,3 • 8.0/75 - 15,3
FRENOS	Hidrostático a las 4 ruedas, De servicio a las ruedas delanteras, de estacionamiento a las
CAPACIDAD RECOGEDOR BARREDORA	ruedas.
DESCARGA TOLVA	245 L
VELOCIDAD BARRIDO	Frontal
ANCHO TOTAL (con cepillos laterales)	7 Km/h
ANCHO DE BARRIDO	1.800 - 2.100 mm.
Nº DE CEPILLOS LAT.	1.800 - 2.100 mm.
ANCHO CEPILLO CENTRAL	2
DIÁMETRO CEP. CENTRAL	1.200 mm
DIÁMETRO CEPILLO LATERAL	560 mm
CAPACIDAD DEPÓSITO DE AGUA ANTI-POLVO	610 mm
BOMBA DE AGUA	435 L
ANCHO TOTAL DE RIEGO	Eléctri. 5 atm. 2.100 mm. Sistema de cambio automático para intercambio de sistema de barrido y pala



WATER LEVEL	835 Ltrs.
FULL TO THE BRIM	1,2 m ³
MAX. GRADABILITY	42%
ENGINE	Diesel Perkins, 3 C. 36 H.P. Water cooled
TRANSMISSION	REXROTH Hidro. variable flow pump
SPEEDS	Slow: 0 - 9 Km/h. • Fast: 0 - 20 Km/h.
STEERING	Hydr. on the rear axle
WHEELS	10.0/75 - 15,3 • 8.0/75 - 15,3
BRAKES	Hydrostatic for 4 wheels, Service Brakes: Acting front wheels. Parking: Mechanic on front axle.
SWEeper CAPACITY	245 L
HOPPER UNLOADING	Front
SWEEPING SPEED	7 Km/h
TOTAL WIDTH (lateral brushes included)	1.800 - 2.100 mm
SWEEPING WIDTH	1.800 - 2.100 mm
NUMBER OF LATERAL BRUSH	2
CENTRAL BRUSH WIDTH	1.200 mm
CENTRAL BRUSH DIAMETER	560 mm
LATERAL BRUSHES DIAMETER	610 mm
CAPACITY OF WATER SUPPLY FOR SRINKLING	435 L
WATER PUMP	Eléctri. 5 atm.
TOTAL SPRINKLING WIDTH	2.100 mm. Automatic switching system for exchanging sweep and shovel device.



NIVEAU DE EAU	835 Ltrs.
PLEIN	1,2 m ³
DECLIVITE MAX.	42%
MOTEUR	Diesel Perkins, 3 C. 36 H.P. Par eau
TRANSMISSION	REXROTH Hidrostatique variable flow pump
VITESSES	Lente: 0 - 9 Km/h. • Rapide: 0 - 20 Km/h.
DIRECTION	Hydrostatique pont arriere
ROUES	10.0/75 - 15,3 • 8.0/75 - 15,3
FREINS	Hydrostatic a les 4 roues, Frein de Service: Sur le front roues Frein de stationnement: Sur l'abre de
CAPACITÉ BAC BALAYEUSE	transmission pont avant.
DÉVERSEMENT DE LA BENNE	245 L
VITESSE DE BALAYAGE	Frontal
LARGEUR TOTAL (avec balais latéraux)	7 Km/h
LARGEUR BALAYAGE	1.800 - 2.100 mm
NUMERO DE BLAIS LATÉRAUX	1.800 - 2.100 mm
LARGEUR DU BALAI CENTRAL	2
DIAMÈTRE DU BALAI CENTRAL	1.200 mm
DIAMÈTRE DES BALAIS LATÉRAUX	560 mm
CAPACITÉ DU RÉSERVOIR DU EAU D'ARROSAGE	610 mm
POMPE À EAU	435 L
LARGEUR TOTAL ARROSAGE	Eléctri. 5 atm. 2.100 mm. Système de commutation automatique d'échange pour le balayeuse et le système de pelle

Tarifa de Precios • Tariff of Prices • Tarif de Prix

REF: Descripción • Description • Description

DH-200 BA Dumper Barredora / Dumper-Sweeper / Dumper-Balayeuse



AGRIA HISPANIA, S.A.
Telf.: + 34 94 630 00 55 · Fax: + 34 94 630 01 35
E-mail: jlecue@agria.net · jgomez@agria.net
<http://www.agria.net>
Apartado 26 · B° Euba, s/n.
48340 AMOREBIETA (Vizcaya) ESPAÑA

